

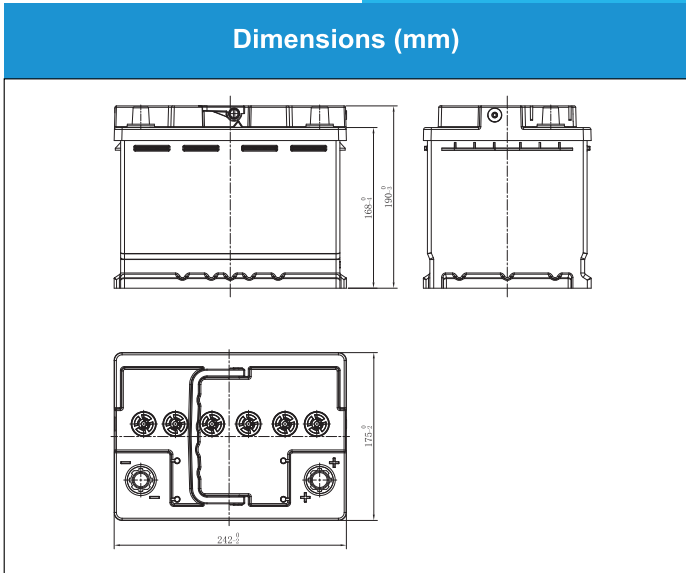

# LEOCH®

## AGM-L2 (12V 60Ah)



### Physical Specification (mm)

Nominal Voltage		12V
Nominal Capacity(20HR)		60Ah
Dimension	Length	242 +0/-2mm(9.53inches)
	Width	175 +0/-2mm(6.89inches)
	Container Height	190 +0/-3mm(7.48inches)
	Total Height(with Terminal)	190 +0/-3mm(7.48inches)
Weight		Approx 18.6Kg(41.01lbs)
Standard Terminal		1
Cell layout		0
Hold-Down		B13
Cell plate qty		/
Case		Black-PP Material
Cover		Black-PP Material
Handle		Black-PP Material

### Electrical Specification

Rated Capacity	20 hour rate(3.0A)	60Ah
Reserve Capacity	100min	
Cold Cranking Performance Amps@0°F(-18°C)	660A	

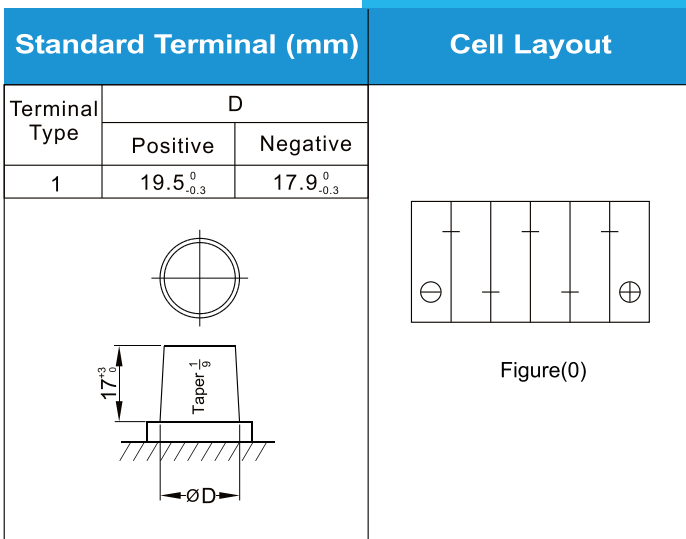

### Discharge Characteristics(-18°C,0°F)

